

Operating Instructions for the TAKE-A-LABEL Model TAL-450-18

Note: The TAKE-A-LABEL dispenser is shipped mounted to a base to prevent shifting in the container.

1. Remove the machine from the base.
Always load the TAKE-A-LABEL dispenser with the On-Off Switch in the (OFF) position.
2. To load a roll of labels on the TAKE-A-LABEL, loosen the unwind hub screw (57) on the unwind collar (56) and remove the collar, unwind washer, unwind spring, and disc from the unwind shaft.
3. Place the roll of labels on the unwind shaft between the two unwind discs. Place the roll with the beginning of the roll on the bottom with the web dispensing to your right as you face the side of the machine.
4. Replace the unwind disc, unwind spring, and collar onto unwind shaft. If using labels on a 3" diameter core, the hub on each disc will fit inside the core and support the roll of labels. If the labels are on a 1" core, simply slide the disc up snugly against the roll of labels. When the disc is in place, tighten the unwind hub screw against unwind shaft.
5. Thread the loose end of labels under and up the front of the peel plate.
6. Pull the labels over top of peel plate far enough to reach the waste take-up roll.
7. Remove the waste wind clip, thread label backing paper under clip, and reinsert clip over loose paper.
8. Position the Photo Eye or Micro Switch Assembly by loosening wing nuts and moving assembly to right or left so that the sensor is at or near the center of the labels. The Photo Eye or Micro Switch Assembly can be tilted forward or backward by loosening the mounting bracket vertical adjustment wing nut.



9. Turn on On-Off switch. The waste wind shaft will turn, winding up backing paper and dispensing a label at the top of the peel plate. When the Photo Eye or Micro Switch senses the dispensed portion of the label, the motor will stop. As each label is removed, the machine will operate until the next label is in position to be removed. **(CAUTION:) Turn off switch before removing wound up waste.**
10. If labels tend to follow backing paper over the top of the peel plate instead of peeling off, then there is insufficient tension on the web of the labels. The shaft adjustment collar should be moved in to put more tension on the web.
11. If the motor stalls it may be necessary to move the shaft collar out to reduce the amount of unwind tension.



take-a-label.com • sales@take-a-label.com • 16900 Power Dr., Nunica, MI 49448 • 616.837.9300

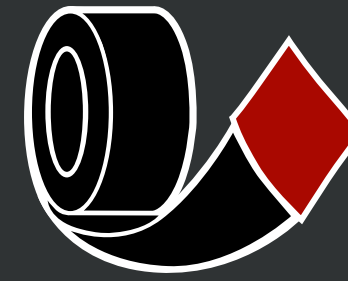

TAKE-A-LABEL

Operating Instructions

General Specifications, Model 450

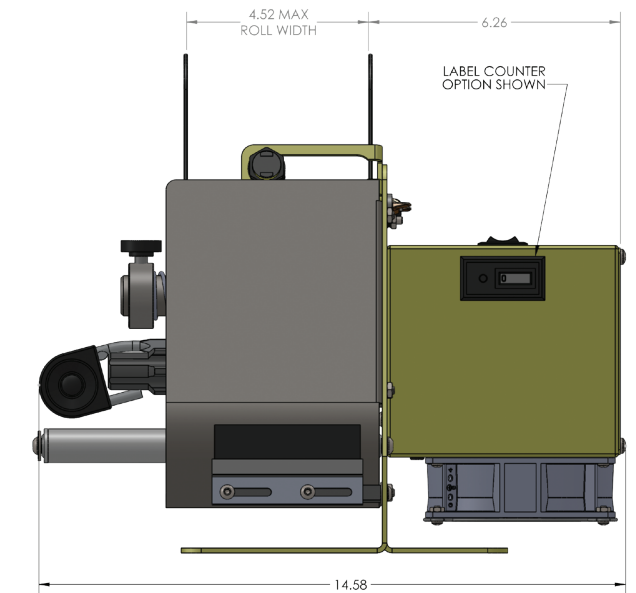
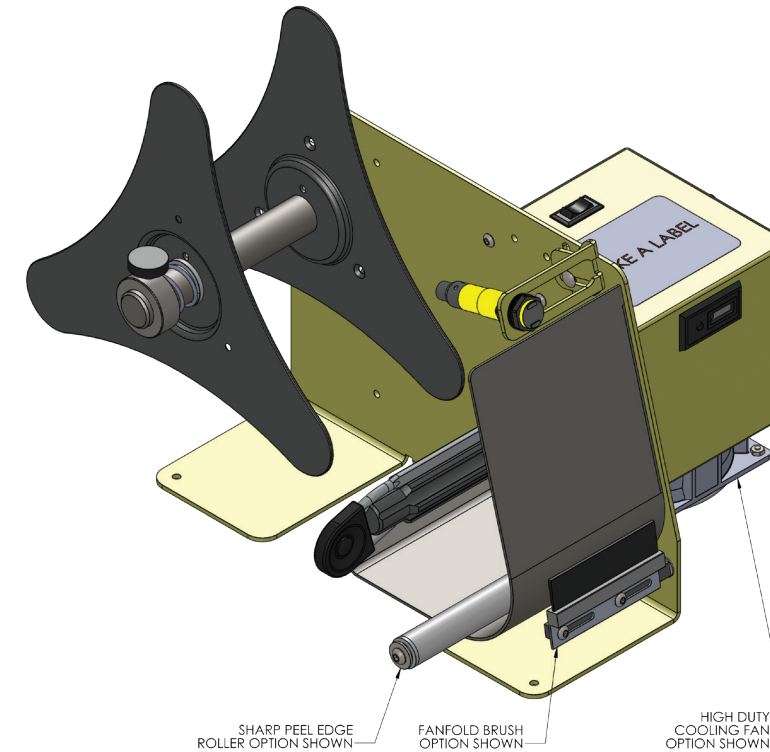

General Specifications, Model 450

Size (Approx.):
14.58W x 12.38H x 18.50D
Shipping Weight:
24 lbs (10.9 KG)
Electrical:
110/120VAC, 50/60HZ,
4 AMP FUSE

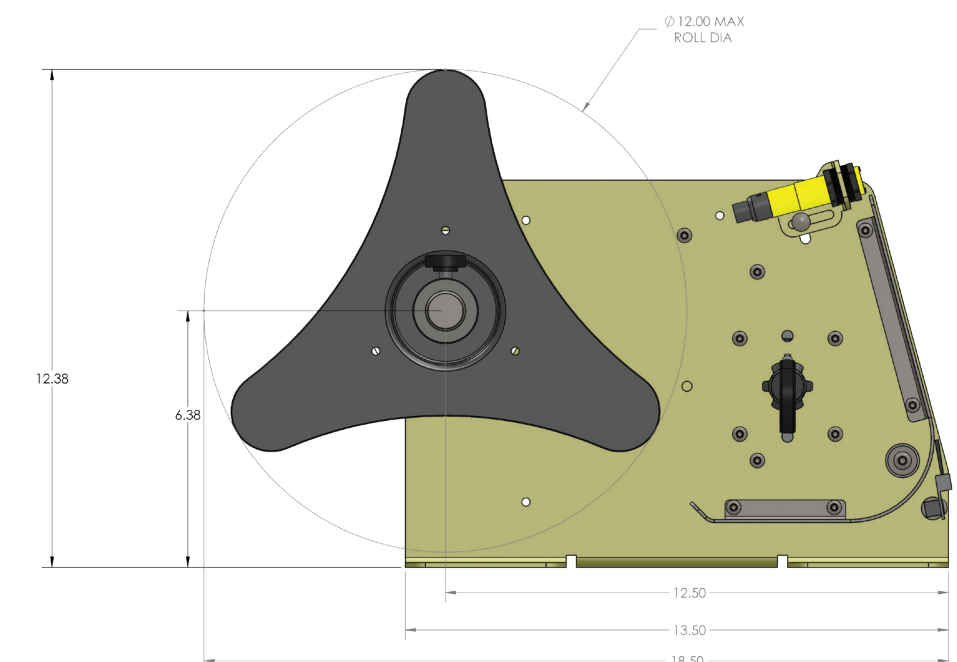

TAL 450 Label Dispenser Exploded View

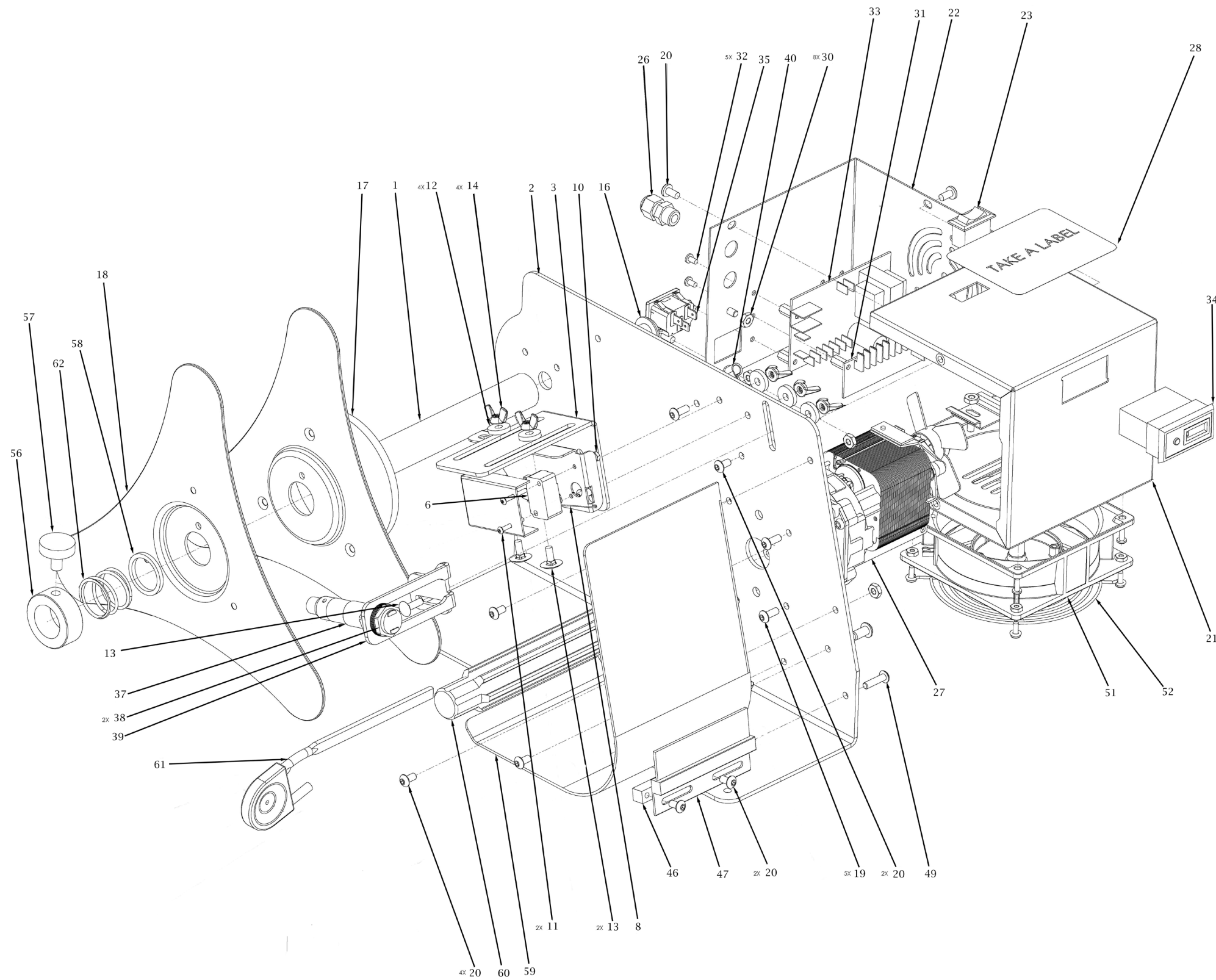

ITEM#	PART NUMBER AND DESCRIPTION	NOTES	QTY.
1	45125, Unwind shaft		1
2	25201, 250, 450, 750 Main frame		1
3	25120, Switch support bracket	Micro Switch-Style Label Sensor	1
6	45307, Micro Switch	Micro Switch-Style Label Sensor	1
8	45308, Trip Wire	Micro Switch-Style Label Sensor	1
Not Shown	45409, Micro Switch Assembly	Complete Assembly 2018 and Newer	1
10	4-40 Hex Nut	Micro Switch-Style Label Sensor	2
11	4-40x0.875 BHCS	Micro Switch-Style Label Sensor	2
12	45182, Washer, nylon		5
13	45181, Carriage Bolt		2
14	45180, Wing Nut		5
16	30653, 1/2-13x.75 BHCS		1
17	72618, Felt Washer		1
18	45136, Unwind Disc		2
19	10-32x0.5 BHCS		5
20	10-32x0.375 BHCS		10
21	25202, 250, 450, 750 Motor housing		1
22	25203, 250, 450, 750 Rear and side cover		1
23	40007, Power On/Off switch		1
26	81912, Small cord grip		1
27	76800, Gear Motor		1
28	45133, Name Plate Label		1
30	10-32 Hex Nut		8
31	45100, Control Board - 250, 450, 750		1
32	6-32x0.25 BHCS		5
33	45102, CS Board- 450, 750 CS	Optional: Used with Special DC Photo Eyes	1
34	30202, Label Counter	Optional: Label Counter	1
35	25211, IEC Outlet, 701wx204		1
Not Shown	25212, IEC Line cord, US	Not Shown	1
37	25213, Photo Eye	Photo Eye Label Sensor	1
38	81904, Photo Eye Ring Nut	Photo Eye Label Sensor	2
39	25204, Photo Eye bracket	Photo Eye Label Sensor	1
40	45186, P-clip		1
46	11006, Brush support bar	Optional: Fan Fold Adapter	1
47	37004, Brush with holder	Optional: Fan Fold Adapter	1
49	10-32x0.75 BHCS	Optional: Fan Fold Adapter	1
50	75834, Heavy Duty Fan	Optional: Heavy Duty Fan	1
51	75835, Fan Guard	Optional: Heavy Duty Fan	1
56	26001, Shaft Collar		1
57	26002, Knob		1
58	25112, Washer		1
59	45124, Peel plate		1
60	45129, TAL-450 Waste Rewind		1
61	45131, Waste Wind Clip		1
62	25113, Unwind Spring		1

COMMON PARTS FOR PRIOR MODEL YEARS

Not Shown	45208, Trip Wire	2014 and Older Models	1
Not Shown	45309, Switch Assembly	2016 and Older Models	1
Not Shown	81905, Photo Eye	2016 and Older Models	1
Not Shown	81906, Relay	2016 and Older Models	1
Not Shown	81907, Relay Socket	2016 and Older Models	1
Not Shown	25119, Lighted On/Off Switch	2007 and Older Models	1
Not Shown	45217, Power Cord	2016 and Older Models	1
Not Shown	45153, Power Cord Clamp	2016 and Older Models	1
Not Shown	45155, Fuse Holder	2016 and Older Models	1
Not Shown	45157, Fuse	2016 and Older Models	1